

# Flowrite™

## 599 Series Rack & Pinion Valves



### Description

The Flowrite 599 Series Rack & Pinion Valve couples the OpenAir™ Actuator to a 1/2- to 2-inch Flowrite 599 Series two- or three-way valve via a linkage. The linkage transforms the actuator rotary movement into the linear motion required to position the valve.

### Features

- Brushless DC motor technology with stall protection
- Bi-directional fail-safe spring return (actuator dependent)
- Direct or reverse acting selectable by field installation
- All metal housing

### Application

The Flowrite valves are used to control water and glycol solutions to 50 percent in small to large air handling units and central plant applications.

### Warning/Caution Notations

**WARNING:**



Personal injury or loss of life may occur if you do not perform a procedure as specified.

**CAUTION:**







Equipment damage may occur if you do not perform a procedure as specified.

**Product Numbers**

Table 1 provides a complete description of the product numbers.

**Table 1. Flowrite 599 Series Rack & Pinion Valve Product Numbers.**

Product Number	Description
298-XXXXX 299-XXXXX 	<p>Assembly consisting of: OpenAir Electronic Actuator, linkage, and 1/2-inch to 2-inch Flowrite two-way or three-way valve body.</p> <p>298-XXXXX includes: OpenAir GCA161.1U Electronic Actuator for 0 to 10 Vdc modulating control with a 24 Vac or 24 Vdc supply voltage.</p> <p>Product number 299-XXXXX includes: OpenAir GCA121.1U Electronic Actuator for 2-position on/off control with a 24 Vac or 24 Vdc supply voltage.</p> <p>The XXXXX of the product number specifies a particular Flowrite two or three-way valve body.</p> <p>For details and complete product numbers, see TB249, <i>Flowrite 599 Series Valve and Actuator Assembly Selection Technical Bulletins</i> (155-772 or 155-776).</p>
599-03609 	<p>Assembly consisting of: OpenAir GCA161.1U Electronic Actuator and linkage.</p> <p>The assembly is ready for field installation on a 1/2- to 2-inch Flowrite two- or three-way valve.</p> <p>For details on the actuator, see <i>OpenAir GCA Series Spring Return 142 lb in Electronic Damper Actuators Technical Instructions</i> (155-173P25).</p>
599-03611 	<p>Assembly consisting of: OpenAir GCA121.1U Electronic Actuator and linkage.</p> <p>The assembly is ready for field installation on a 1/2- to 2-inch Flowrite two- or three-way valve.</p> <p>For details on the actuator, see <i>OpenAir GCA Series Spring Return 142 lb in Electronic Damper Actuators Technical Instructions</i> (155-173P25).</p>
599-03610 	<p>Linkage only.</p> <p>For mounting of an alternate OpenAir electronic actuator on the linkage and installation of that linkage/actuator assembly on 1/2-inch to 2-inch Flowrite two-way or three-way valve.</p>

---

**Specifications**

<b>Power supply</b>	Operating voltage	24 Vac $\pm$ 20%, 24 Vdc $\pm$ 10%
	Frequency	50/60 Hz
	Power consumption 599-03609 assembly (with GCA161.1U actuator)	9 VA running, 5 VA holding
	599-03611 assembly (with GCA121.1U actuator)	8 VA running, 3 VA holding
	Equipment rating	Class 2, in accordance with UL/CSA
<b>Control signal</b>  <b>(599-03609 assembly with GCA161.1U actuator)</b>	Input signal	
	voltage input	0 to 10 Vdc (max. 35 Vdc)
	input resistance	100K ohms
	current input	4 to 20 mA
	input resistance	500 ohms
	Position output feedback signal	0 to 10 Vdc, $\pm$ 1 mA maximum
<b>Ambient conditions</b>	Ambient temperature operation	-25 to 130°F (-32 to 55°C)
	storage and transport	-25 to 158°F (-32 to 70°C)
	Ambient humidity (non-condensing)	95% rh
<b>Mounting</b>	Nominal angle of rotation	90°
	Maximum angular rotation	95°
	Noise level	<45 dBA (running)
	Enclosure	NEMA 2 in vertical to horizontal 90 degrees (see Figure 1)
<b>Linkage</b>	Frame	Aluminum alloy frame
	Construction	Steel rack, pinion and stem shaft pre-lubricated, bronze bushings
<b>Physical characteristics</b>	Pre-connected cable	18 AWG, 3 ft (0.9 m)
	Dimensions	See Figures 2 and 3.
	Weight	8.35 lb (3.79 kg)

---

For Valve specifications, see the following documents:

- *Flowrite™ 599 Series Two-way 1/2 to 2-inch Bronze Valves Technical Instructions (155-184P25)*
- *Flowrite 599 Series Three-Way 1/2 to 2-inch Bronze Valves Technical Instructions (155-185P25)*

For OpenAir™ Electronic Damper Actuator specifications, see the following document:

*OpenAir GCA Series Spring Return 142 lb in Electronic Damper Actuators (155-173P25)*

---

## Operation

### 599-03609 assembly with GCA161.1U actuator

A continuous 0 to 10 Vdc signal from a controller to Terminal Y (8, gray) of a normally-closed, direct-acting assembly operates the actuator and the valve opens respectively. The linkage proportionally translates the rotary actuator stroke into a linear valve stem motion.

A 0 to 10 Vdc position output feedback signal at Terminal U (9, pink) is available to monitor the position of the actuator.

In the event of a power failure or when the operating voltage is absent, the actuator returns to the fail-safe (90°) position and the valve closes.

In the event of a stall, the actuator is overload protected over the full range to prevent damage.

---

### 599-03611 assembly with GCA121.1U actuator

When power is applied to a normally-closed, direct-acting assembly, the actuator moves to the full-open (-5°) position and the valve opens. The linkage translates the rotary actuator stroke into a linear valve stem motion.

In the event of a power failure or when operating voltage is absent, the actuator returns to the fail-safe (90°) position and the valve closes.

In the event of a stall, the actuator is overload protected over the full range to prevent damage.

---

### Life expectancy

An improperly-tuned loop will cause excessive repositioning that will shorten the life of the actuator.

---

## Installation and Mounting

Flowrite Rack & Pinion Valves are suitable for water applications where, the actuator mounts on the linkage vertically. Units are shipped from the factory in the vertical position.

Flowrite Rack & Pinion Valves can be installed on normally-closed, normally-open, and three-way Flowrite valves for direct or reverse-acting control applications. The actuator orientation and the position of the actuator shaft adapter on the linkage determine whether the linkage shaft rotates clockwise or counterclockwise for the proper control action. *Flowrite 599 Series Rack & Pinion Valves Installation Instructions* (129-292), shipped with the assembly, provides details to configure the assembly for the desired control application.

For applications using an alternate OpenAir Electronic Actuator on the linkage, the actuator preload must be reset. *Flowrite 599 Series Rack & Pinion Valves Installation Instructions* (129-292), shipped with the assembly, provides preload details.

Install the Flowrite Rack & Pinion Valve so that the flow of the medium follows the direction of the arrow cast on the valve body. For best performance, install the valve with the actuator above the valve body. Figure 1 shows acceptable NEMA 2 mounting positions. Do not mount the assembly so that the actuator is below horizontal or upside-down.

Allow sufficient space for servicing the assembly. See *Dimensions* and the recommended service envelope in Figure 2.

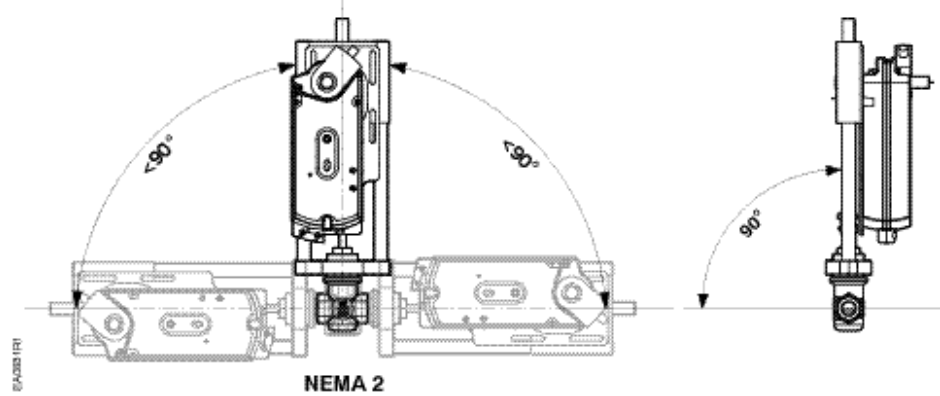

**Figure 1. Acceptable NEMA 2 Mounting Positions.**

**Wiring**

All wiring must conform to NEC, and to local codes and regulations.

Use earth ground isolating step-down Class 2 transformers. Do not use autotransformers.

Determine the supply transformer rating by summing the total VA of all actuators used. The maximum rating for a Class 2 step-down transformer is 100 VA.

Table 2 shows the recommended maximum actuators per Class 2 circuit and includes a safety factor of 80% of the transformer VA. Operating additional actuators requires additional transformers or separate 100 VA power trunks.

<b>Table 2. Recommended Maximum Power Consumption (VA) for a Class 2 Step-Down Transformer.</b>		
<b>Actuator</b>	<b>Power Consumption</b>	<b>Actuator per Class 2 Supply Circuit</b>
GCA12x.	8 VA	10
GCA16x	9 VA	9

## Wiring Diagrams

**599-03609 assembly  
 with GCA161.1U  
 actuator**

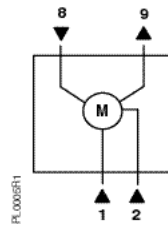

**Table 3. 599-03609 Assembly (with GCA161.1U) for Modulating Control with 24 Vac or 24 Vdc Supply Voltage.**

Standard Symbol	Function	Terminal Connection	Standard Color
1	Supply (SP)	G	Red
2	Neutral (SN)	G0	Black
8	0 to 10 Vdc input signal	Y	Gray
9	Output for 0 to 10 Vdc position feedback indication	U	Pink

**599-03611 assembly  
 with GCA121.1U  
 actuator**

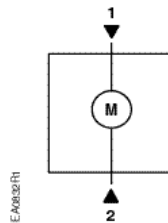

**Table 4. 599-03611 Assembly (with GCA121.1U) for 24 Vac or 24 Vdc Two-Position Control.**

Standard Symbol	Function	Terminal Connection	Standard Color
1	Supply (SP)	G	Red
2	Neutral (SN)	G0	Black

## Start Up/ Commissioning

- Check that the wires are connected correctly.
- For additional actuator information, see *OpenAir™ GCA Series Spring Return 142 lb-in Electronic Damper Actuators* Technical Instructions (155-173P25).

## Service



**WARNING:**

Do not open the actuator.

If the linkage or actuator is inoperative, replace the unit.

For valve service kits, see the following documents:

- *Flowrite 599 Series Two-Way 1/2 to 2-Inch Bronze Valves* Technical Instructions (155-184P25)
- *Flowrite 599 Series Three-Way 1/2 to 2-inch Bronze Valves* Technical Instructions (155-185P25)

## Dimensions

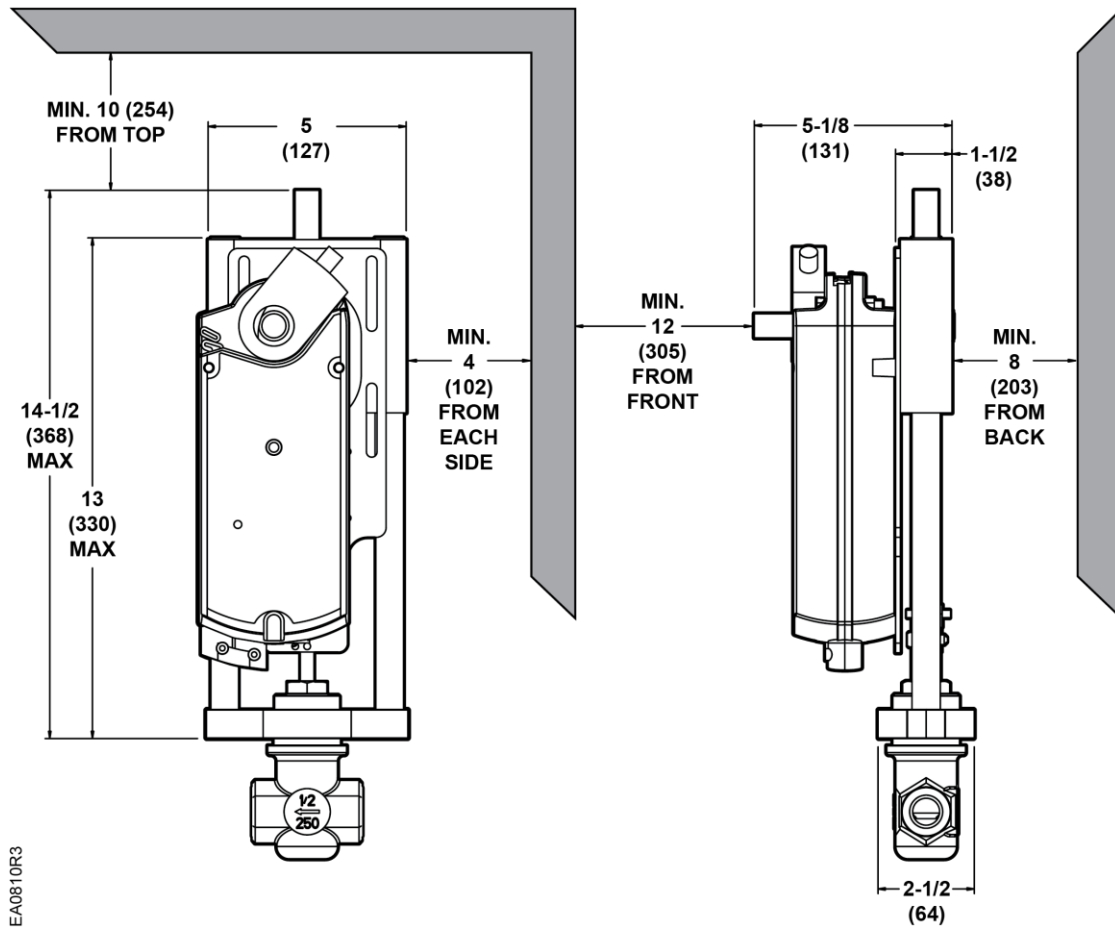

**Figure 2. Dimensions of the Flowrite 599 Series Rack & Pinion Valve in Inches (Millimeters).**

**NOTES:** For valve dimensions, see the following documents:

- *Flowrite 599 Series Two-Way 1/2- to 2-inch Bronze Valves* Technical Instructions (155-184P25)
- *Flowrite 599 Series Three-Way 1/2 to 2-inch Bronze Valves* Technical Instructions (155-185P25)

Information in this publication is based on current specifications. The company reserves the right to make changes in specifications and models as design improvements are introduced. OpenAir and Flowrite are registered trademarks of Siemens Industry, Inc. Other product or company names mentioned herein may be the trademarks of their respective owners. © 2018 Siemens Industry, Inc.